

R13

Code No: 113BJ

JAWAHARLAL NEHRU TECHNOLOGICAL UNIVERSITY HYDERABAD

B. Tech II Year I Semester Examinations, September/October - 2023

STRENGTH OF MATERIALS – I

(Civil Engineering)

Time: 3 Hours

Max. Marks: 75

Note: i) Question paper consists of Part A, Part B.

ii) Part A is compulsory, which carries 25 marks. In Part A, answer all questions.

iii) In Part B, Answer any one question from each unit. Each question carries 10 marks and may have a, b as sub questions.

PART - A**(25 Marks)**

- 1.a) Define plasticity. [2]
- b) A rectangular bar made of steel is 3 m long and 30 mm thick. The rod is subjected to an axial tensile load of 30 kN. The width of the rod varies from 75 mm at one end to 30 mm at the other. Find the extension of the rod if $E = 200$ GPa. [3]
- c) Distinguish between a cantilever and a simply supported beam [2]
- d) Derive the expressions for SFD and BMD for a cantilever of length L carrying a point load W at the free end. [3]
- e) What is neutral axis in pure bending? [2]
- f) Prove that, in a rectangular section, the maximum shear stress is 1.5 times the average stress. [3]
- g) What is Maximum Principal Strain Theory? [2]
- h) Draw the Mohr's circle of stresses for a body experiencing direct stresses in two perpendicular directions and an added simple shear stress. [3]
- i) Sketch the conjugate for the continuous beam shown in Fig. 1 [2]



Fig. 1

- j) Derive the equation of the elastic curve and deflection of a cantilever beam subjected to a point load at its free end. Assume EI to be constant. [3]

PART - B**(50 Marks)**

2. A steel rod of 20 mm diameter passes centrally through a copper tube 40 mm external diameter and 30 mm internal diameter. The tube is closed at each end by rigid plates of negligible thickness. The nuts are tightened lightly home on the projected parts of the rod. If the temperature of the assembly is raised by 50°C , Determine the stresses developed in copper and steel. Assume E for steel and copper as 200 GPa and 100 GPa respectively and α for steel and copper as $12 \times 10^{-6}/^\circ\text{C}$ and $18 \times 10^{-6}/^\circ\text{C}$. [10]

OR



3. Derive the strain energy stored within a bar of uniform cross-section A and length L hanging vertically and subjected to its own weight. [10]



4. Analyse and construct the shear-force and bending moment diagrams for the beam shown in Fig.2. Label all significant points on each diagram and identify the maximum moments along with their respective locations. Clearly differentiate straight-line and curved portions of the diagrams. [10]

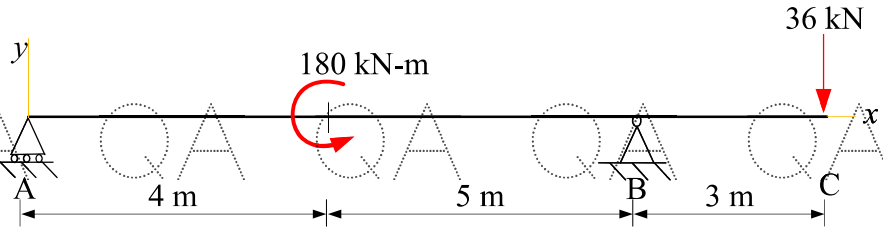

Fig.2

OR



5. Construct the shear-force and bending moment diagrams for the over-hanging beam carrying uniformly distributed load of 3 kN/m over the entire length as shown in Fig.3. Clearly differentiate straight-line and curved portions of the diagrams. Also locate the point of contraflexure. [10]

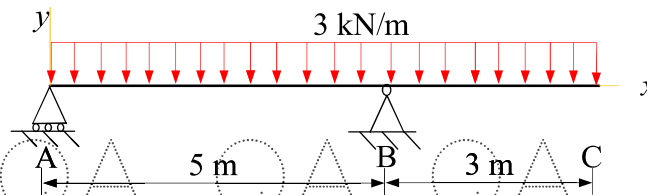

Fig.3

6. A beam having a T-section (as shown in Fig. 4) is subjected to 12 kN-m bending moment (sagging). Determine the following:
- Bending stress at point A. State whether the normal stress at A is tension or compression.
 - Maximum bending stress produced in the cross-section. Stat whether it is tension or compression.
- [10]

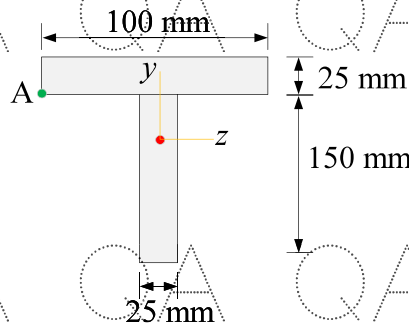

Fig. 4

OR

7. Derive the shear stress formula using appropriate notations. [10]



QA QA QA QA QA QA QA

8. Consider a point in a structural member which is subjected to plane stress. Normal and shear stresses acting on horizontal and vertical planes at the point are shown in Fig. 5.

- Draw the Mohr's circle for this state of stress.
 - Determine the principal stresses and maximum in-plane stress acting at the point using Mohr's circle.
 - Show these stresses with a suitable sketch.
- [10]

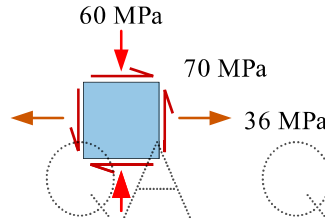

Fig.5
OR

9. Given principal stresses: $\sigma_1 = 120$ MPa (tensile), $\sigma_2 = 80$ MPa (tensile), $\sigma_3 = 50$ MPa (compressive). The elastic limit in simple tension is 200 MPa. Determine if material failure occurs using the maximum principal stress theory and calculate the factor of safety if failure doesn't occur.

[10]

10. Determine the slope and deflection at points A, B, C and D using conjugate beam method for the beam shown in Fig. 6. Use $I = 130 \times 10^6 \text{ mm}^4$ and $E = 200$ GPa.

[10]

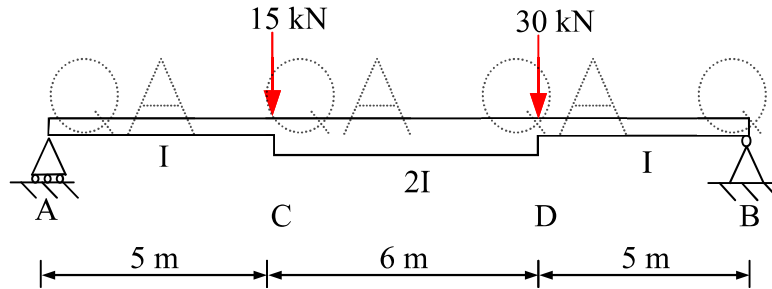

Fig.6
OR

11. Use double-integration method for the beam shown in Fig. 7 to determine the following.

- Equation of elastic curve for the beam
- Slope at the point A and B.
- Deflection at mid-span.

Assume that EI to be constant.

[10]

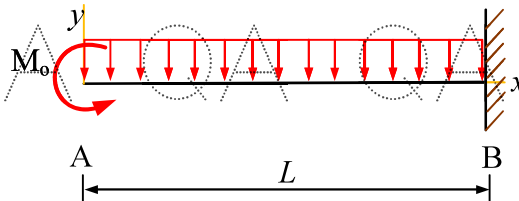

Fig.7

QA QA QA QA QA QA QA